



# Pool Power Pak<sup>®</sup> I

UL/CSA Models 0-1063-000, 0-1064-000,  
0-1065-000, 0-1066-000

NEC/UL Models 0-1063-006, 0-1064-006,  
0-1065-006, 0-1066-006

---

---

## Owner's Guide

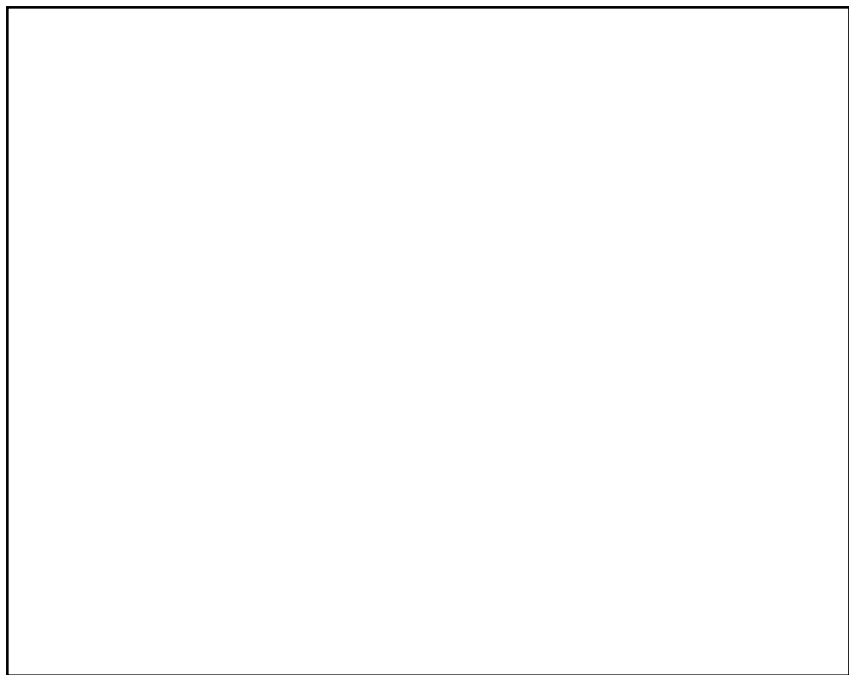

U.L. Listed



Certified by the  
Canadian Standards Association



## PREPARATION

### IMPORTANT SAFETY INSTRUCTIONS

#### FOR ALL MODELS:

When installing and using this electrical equipment, basic safety precautions should always be followed, including the following:

1. **READ AND FOLLOW ALL INSTRUCTIONS.**

2. **WARNING:** To reduce the risk of injury, do not permit children to use this product unless they are closely supervised at all times.

3. **WARNING:** Risk of electric shock. Connect only to a grounding type receptacle protected by a Ground Fault Interrupter (GFCI). Contact a qualified electrician if you cannot verify that the receptacle is protected by a GFCI.

4. Do not bury cord. Locate cord to minimize abuse from lawn mowers, hedge trimmers, and other equipment.

5. **WARNING:** To reduce the risk of electric shock, replace damaged cord immediately.

6. **WARNING:** To reduce the risk of electric shock, do not use an extension cord to connect unit to the electrical supply; provide a properly located outlet.

#### FOR UL/CSA MODELS ONLY:

0-1063-000, 0-1064-000  
0-1065-000, 0-1066-000

7. **CAUTION:** This pump is for use with storable pools only. Do not use with permanently installed pools. A storable pool is constructed so it may be readily disassembled for storage and reassembled to its original integrity. A permanently installed pool is constructed in or on the ground or in a building such that it cannot be readily disassembled for storage.

#### FOR NEC/UL MODELS ONLY:

0-1063-006, 0-1064-006  
0-1065-006, 0-1066-006

8. **CAUTION:** This pump is for use with permanently installed pools and may also be used with hot tubs and spas if so marked. Do not use with storable pools. A permanently installed pool is constructed in or on the ground or in a building such that it cannot be readily disassembled for storage. A storable pool is constructed so that it may be readily disassembled for storage and reassembled to its original integrity.

#### FOR ALL MODELS:

9. SAVE THESE INSTRUCTIONS.

### ELECTRICAL SOURCE

#### FOR UL/CSA MODELS ONLY:

0-1063-000, 0-1064-000  
0-1065-000, 0-1066-000

Your pump is supplied with a 25 foot, 3-wire electrical cord and a 3-pronged plug. The pump is double insulated and grounded. The pump electrical cord must be connected to a grounded, 3-wire, 115 VAC electrical receptacle.

The pump should be connected to a receptacle on a dedicated circuit protected by a 20 AMP circuit breaker. **DO NOT** use a grounding adaptor.

The receptacle must be protected by a Ground Fault Circuit Interrupter (GFCI) in accordance with Article 680-31 of the National Electrical Code (NEC), (Section 68-204 of the Canadian Electrical Code (CSA) and local codes or ordinances. For runs greater than 25 feet, consult your local licensed electrical contractor.

#### FOR NEC/UL MODELS ONLY:

0-1063-006, 0-1064-006  
0-1065-006, 0-1066-006

Your pump is supplied with a 3-foot, 3-wire electrical cord and a 3-prong flanged, twist-lock plug.

The pump electrical cord must be connected to a single twist lock, grounding type receptacle that is located a minimum of 5 feet from the inside pool wall.

A qualified electrical contractor must install this receptacle in accordance with Article 680-6 of the National Electrical Code (NEC). A Ground Fault Interrupter (GFCI) must be used. An ON/OFF Switch must be installed at the receptacle.

Use a Hubbell No. 2310 Receptacle, 20 AMP 125 Volt A.C. or an equivalent receptacle that meets NEMA Configuration L5-20R.

This pump is double insulated and grounded. Dead metal parts are not in contact with pool water.

### CAUTION

1. **DO NOT** install the pump on a deck, it could fall into the water, causing severe electrical shock. Do not install on any surface at, above, or slightly below the top rail of the pool.
2. **DO NOT** allow children or adults to climb, sit, or stand on the pump unit. They could easily fall. Position the filter and pump approximately 4 feet from the pool wall so they may not be used as steps by children.
3. Always keep the water level in your pool between the water level markers on the skimmer face plate. If the pump is run with water level too low, the pump seal may overheat and cause permanent damage to the pump.
4. Your Pool Power Pak must sit either in an optional filter/pump base, on a patio block, or on any firm surface that slightly elevates the pump off the ground. This keeps water away from the motor and prevents the vents of the Power Pak from becoming blocked, which could cause the motor to overheat.

**POOL POWER PAK® I EXPLODED VIEW AND PARTS LIST**  
**UL/CSA Models: 0-1063-000, 0-1064-000, 0-1065-000, 0-1066-000**  
**NEC/UL Models: 0-1063-006, 0-1064-006, 0-1065-006, 0-1066-006**

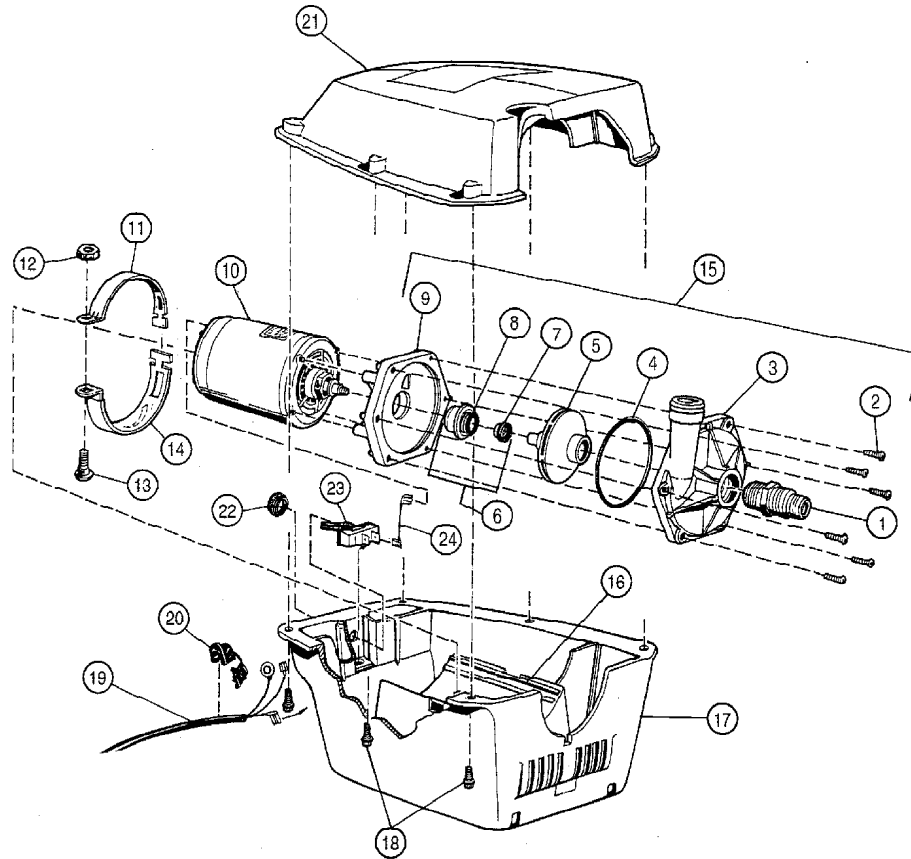

ITEM	P/N	QTY	DESCRIPTION	ITEM	P/N	QTY	DESCRIPTION
1	340-1778	1	Male Hose Adaptor	<b>UL/CSA MODELS 0-1063-000, 0-1064-000, 0-1065-000, 0-1066-000 ONLY</b>			
2	330-1016	6	#8 x 1" Phillips Screw				
3	305-1010	1	Pump Volute	22	303-1110	1	Knurled Ring Nut
4	308-1005	1	O-Ring Seal	23	303-1109	1	Switch
5	1107-1143	1	Impeller Assy., 1/3 HP	24	1100-1078	1	Switch Wire Assy.
	1107-1142	1	Impeller Assy., 1/2 HP	<b>ALL MODELS</b>			
	1107-1141	1	Impeller Assy., 3/4 HP & 1 HP				
6	1121-1577	1	5/8" Pump Seal Set	25	365-1866	—	Owner's Guide
7	308-1263	1	Pump Seal Seat-Ceramic	26		1	Warranty Card
8	308-1264	1	5/8" Pump Seal-Spring				
9	1121-1582	1	Pump Faceplate Assy.				
10	300-1015	1	Motor, 1/3 HP				
	300-1016	1	Motor, 1/2 HP				
	300-1017	1	Motor, 3/4 HP				
	300-1043	1	Motor, 1 HP				
11	385-1152	2	Motor Clamp				
12	321-1004	1	1/4"-20 Hex Nut				
13	324-1018	1	1/4"-20 x 1" Bolt				
14	341-1123	1	Insulating Sleeve				
15	1121-1583	1	1/3 HP Pump Assy.				
	1121-1584	1	1/2 HP Pump Assy.				
	1121-1585	1	3/4 & 1 HP Pump Assy.				
16	348-1026	2	Rubber Strip				
17	1150-1000	1	Bottom Housing Assy.(UL/CSA)				
	1150-1005	1	Bottom Housing Assy.(NEC/UL)				
18	330-1023	6	#8 x 5/8" Screw				
19	1100-1084	1	Cord Set Assy, 25'(UL/CSA)				
	1100-1108	1	Cord Set Assy, 3' (NEC/UL)				
20	303-1104	1	Strain Relief Bushing (UL/CSA)				
	303-1120	1	Strain Relief Bushing (NEC/UL)				
21	1150-1002	1	Top Housing				

## STRAINER ASSEMBLY INSTALLATION

The numbers in parentheses refer to key numbers on the Exploded Parts Illustration.

The Strainer Assembly is packed with the filter. Refer to that Owner's Guide to learn how to install the Strainer Assembly on the Pool Power Pak I. The male hose adaptor (1) provided with your Power Pak is not required

**Skim Line Filter** - Strainer Assembly is optional. If not used, then screw the male hose adaptor (1) into the threaded suction port of the pump volute (3) and tighten firmly. This adaptor must be installed if no Strainer Assembly is used.

## MAINTENANCE

**Make sure the pump is disconnected from the electrical source before attempting any maintenance work.**

## LUBRICATION

Periodically lubricate the O-Ring under the strainer cover with a NON-PETROLEUM lubricant recommended for A.B.S., Noryl and Acrylic plastics. Consult your pool dealer for lubricant selections.

If you have any questions or require assistance, contact your Doughboy pool dealer.

## SERVICING SAFETY TIPS

A. **ALWAYS TURN "OFF"** the main power switch and the Ground Fault Circuit Interrupter (GFCI) breaker switch so power is completely off before servicing your unit.

B. **ALWAYS BE SURE THE GROUND UNDER YOUR FEET AND YOUR BODY IS DRY** before you touch electrical equipment. Failure to heed this warning may cause personal injury due to severe electrical shock.

C. **ALWAYS** have a qualified electrician service your system if electrical problems occur. This system is UL listed and must be serviced by a qualified electrician to insure that the electrical integrity is maintained. Failure to do so may cause personal injury due to severe electrical shock and may void the UL listing and warranty.

D. **ALWAYS** have a qualified electrician install a Ground Fault Circuit Interrupter (GFCI) breaker at the electrical service or supply panel. Follow GFCI manufacturer's operating instructions for testing. Failure to do so may cause personal injury due to severe electrical shock.

**CAUTION:** To reduce the risk of electrical shock, connect only to grounding type receptacles. A Ground Fault Circuit Interrupter (GFCI) must be provided in accordance with local codes or ordinances.

**CAUTION:** To reduce the risk of electric shock, use only Original Equipment Manufactured (OEM) replacement parts when servicing.



**Change of Design:** Doughboy Recreational expressly reserves the right to change or modify the design and construction of any product in due course of our manufacturing procedures, without incurring any obligation or liability to furnish or install such changes or modifications on products previously or subsequently sold.



**DOUGHBOY RECREATIONAL • 10959 Jersey Blvd. • Rancho Cucamonga, CA 91730**  
Visit our website at [www.doughboy-pools.com](http://www.doughboy-pools.com)